

APPLICATIONS NOTE

STS 5800 Expansion Capability

Users sometimes need to expand the output capability of the basic 5800 system beyond the normal 10-DS1 signal limit. This can be done with a second properly equipped 5800 system.

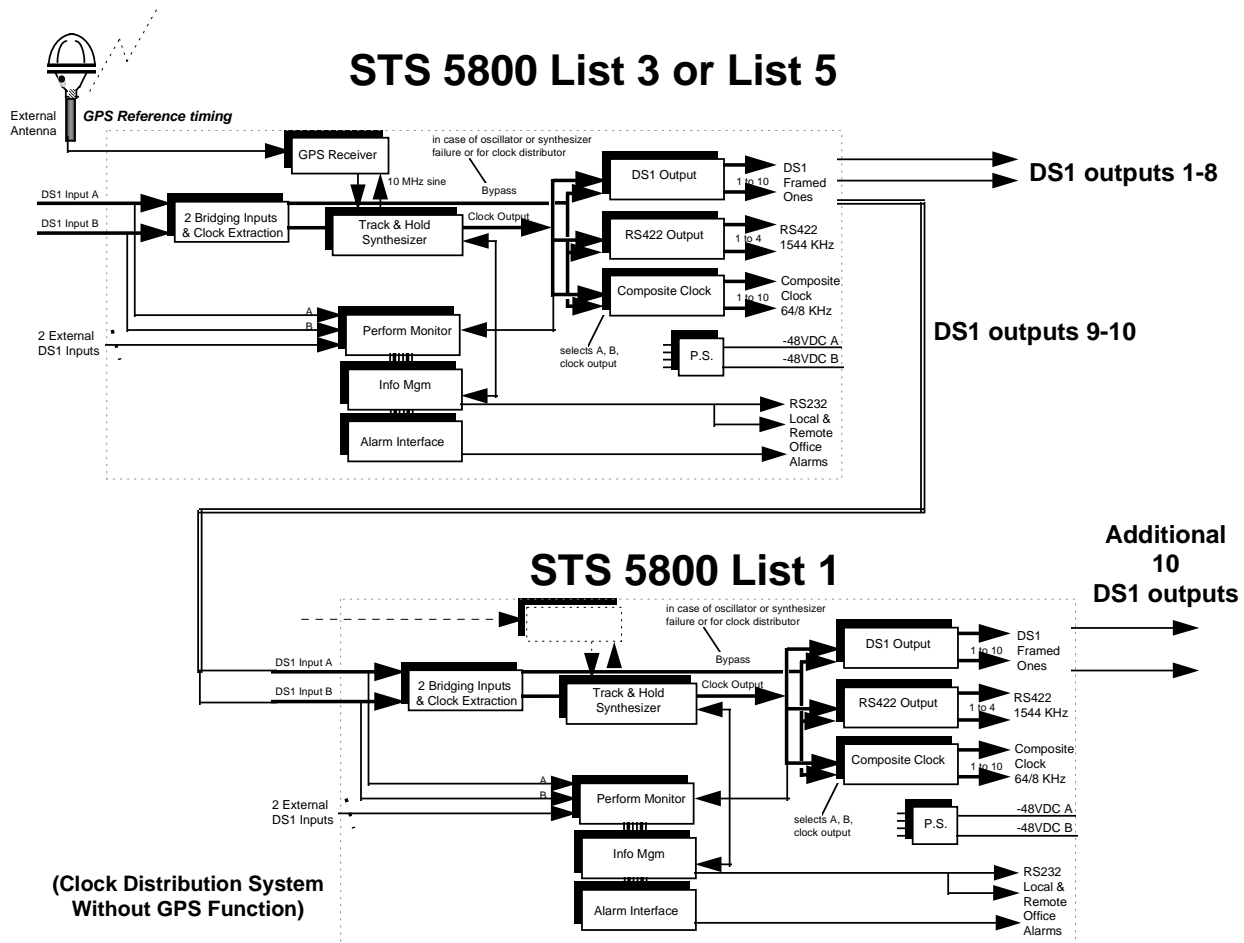

Basically, eight DS1 outputs of the first system are available in the normal fashion. Two output signals are wired down to the expansion system inputs. This expansion system adds ten DS1 outputs, so this gives a total possible capacity of 18 DS1 outputs from the two systems in cascade. This same concept may be extended to three systems, if desired. However, it may be far more practical to consider the Larus STS 5400 system with a DS1 output capacity of 100 per shelf.

The Major and Minor alarm contact closures of the systems are then connected in parallel.