

Highlights

- 200 Outputs per system
- Specialized inputs cards providing T1, 1.544MHz, E1, 2.048MHz and CC, 5/10MHz sinewave
- Stratum 1/Primary Reference Clock (PRC), Stratum 2/Transit Node Clock (TNC), or Stratum 3E/Local Node Clock (LNC) Synchronization Timing System
- Stratum 2/TNC and Stratum 3E/LNC reference oscillators
- Specialized output cards providing DS1, Composite Clock (CC), E1, 2.048MHz Square Wave, RS-422 (1.544MHz or 8kHz Square Wave), Time of Day (TOD), 5/10MHz sine, Network Time Protocol (NTP) with InterRange Instrumentation Group (IRIG-B)
- Outputs are synchronized to one of two redundant input references
- Monitor performance of up to 10 inputs
- Synchronization status messages meet Bellcore GR-378 and ANSI T1X1.3 TR-33
- Redundant power feeds
- Network Equipment-Building System (NEBS) Level 3 certification: GR 63, 78, 1089 COR
- NEBS 19-/23-inch rack mounting
- Patented Direct Digital Frequency Synthesizer (DDFS) for all Stratum levels (CleverClock™ oscillator predictability algorithm)
- TCP/IP and RS-232 ports for remote system configuration and reporting
- Hitless switching between input references, clock cards and protected outputs
- Simple Network Management Protocol (SNMP)
- Graphical User Interface (GUI)
- Phase locked CC outputs
- Earthquake protected
- -48VDC power
- Conforms with all relevant Bellcore documentation

The **CXR/Larus StarClock 200™** is a totally integrated system for use in T1, E1, 2.048MHz, CC, 5 and 10MHz synchronization applications. The StarClock 200 system provides flexible and cost effective solutions to Stratum 1/PRC, 2/TNC, and 3E/LNC digital transmission timing and synchronization applications. The system employs in either DS1 or E1 environments simply by selecting the appropriate modules.

The StarClock 200 circuit card provisioning settings and operating functions are software generated, affording both speed and flexibility in system application changes, testing, and monitoring. Except for the 5/10MHz and NTP output card selections, each of the output cards provides 20 outputs and the CXR/Larus rack-mounted shelf can accommodate up to 10 output cards. The maximum number of outputs per shelf is 200, which can be arranged in 100 protected pairs if desired. Optional modules include track and hold cards with integral DS1/E1 or GPS or receivers. Designed to provide timing for transmultiplexers, Digital Access and Crossconnect Systems (DACS), SONET equipment, digital switches, and channel banks.



The StarClock 200 offers internal system monitoring and performance measurement combined with remote and local reporting in TL1 format or pull down menu. All system configurations, including GPS, DS1 and E1 clocks are mounted in the system shelf and operate in similar or dissimilar pairs. Stratum upgrades are achieved by replacing plug-in circuit packs. Performance measurement and monitoring as well as local and remote reporting features can be selected initially or installed later as system upgrades. Output protection is available. A locking bar prevents accidental card movement.

The StarClock 200 systems (Stratum 1, 2, and 3E versions) use two 54511 T1, 54512 E1/2.048MHz, or 54513 CC, 5/10MHz Input Cards. Stratum 3E/LNC systems add two 54522 Stratum 3E/LNC Track and Hold Cards, while Stratum 2E, 2/TNC configurations include two 54523 2E, Stratum 2/TNC Track and Hold Cards. Stratum 1/PRC configurations are equipped with two 54591 GPS Stratum 1/PRC Track and Stratum 3E/LNC Hold Cards (Stratum 3E holdover) or two 54593 GPS Stratum 1/PRC Track and Stratum 2/TNC Hold Cards (Stratum 2 holdover). Each 54591 and 54593 module incorporates a radio receiver and timing processor for use with either the Global Positioning System of satellites or transmitted cellular carrier.

Performance above STR2 and ST3E is accomplished by a predictability algorithm, CleverClock™ that corrects for the drift characteristic of a given oscillator.

Input cards convert inputs into reference timing for the track and hold circuits. The track and hold cards provide the essential features of phase tracking, jitter smoothing, and holdover clock on input reference failure. Output driver cards supply any mix of twenty DS or E1 framed all-ones, CC, 2.048MHz Square Wave, 1.544MHz EIA RS-422 Square Wave, 8kHz EIA RS-422 Square Wave, and TOD outputs or four 5/10MHz outputs for driving D type channel banks, DACS, transmuxes (LTs), PBXs, or other network transmission and switching equipment. The clock cards typically lock on multiple satellites, but will lock to one satellite and provide the required tracking accuracy.

CXR/Larus StarClock 200

Two additional modules, the Network Time Server plug-in Card 54580 enable NTP and IRIG-B outputs, and the Output Protection Unit 54585, which provides output protection from failed output timing between outputs from separate shelves. Output protection, card-to-card, in the same shelf is provided by the output cards and does not require the 54585 unit.

Stratum Definitions

Stratum 1/PRC

The stratum normally tracks Cesium or GPS input signals from four to eight satellites maintained to be traceable to UTC time to an accuracy of 1×10^{-11} . The unit is also capable of deriving timing when tracking only one satellite. If no GPS input is available, the 54593 or 54591 card will track a connected input reference or, in the absence of inputs, operate in holdover mode as ST2 or ST3E from an internal rubidium (54593) or crystal (54591) oscillator.

Stratum 2/TNC/Stratum 2E

The stratum racks an input under normal conditions, and holds to the last best estimate during impaired conditions. The long term drift with no input reference is less than 1.6×10^{-8} in one year for ST2 and 1×10^{-8} per year for ST2E. The short term drift is less than 1×10^{-10} in 24 hours, equivalent to one frame slip in 7 days in holdover mode. CXR/Larus' Stratum 2 clock drifts less than 7.5×10^{-11} per day, or the first frame slip in about 9.6 days. In reality, the first frame slip will happen in about 60 days under typical conditions. The ST2E drift is less than 1×10^{-11} per day at 22 °C.

Stratum 3E/LNC

The stratum tracks input signals within ± 7.1 Hz of 1.544MHz from a Stratum 3 or better source. The drift with no input reference is less than 5×10^{-9} in 24 hours. This equates to less than two frame slips in 24 hours as compared to 255 slips for Stratum 3. Typical drift performance is less than 9×10^{-10} in 24 hours and less than one slip in 36 hours.

Application

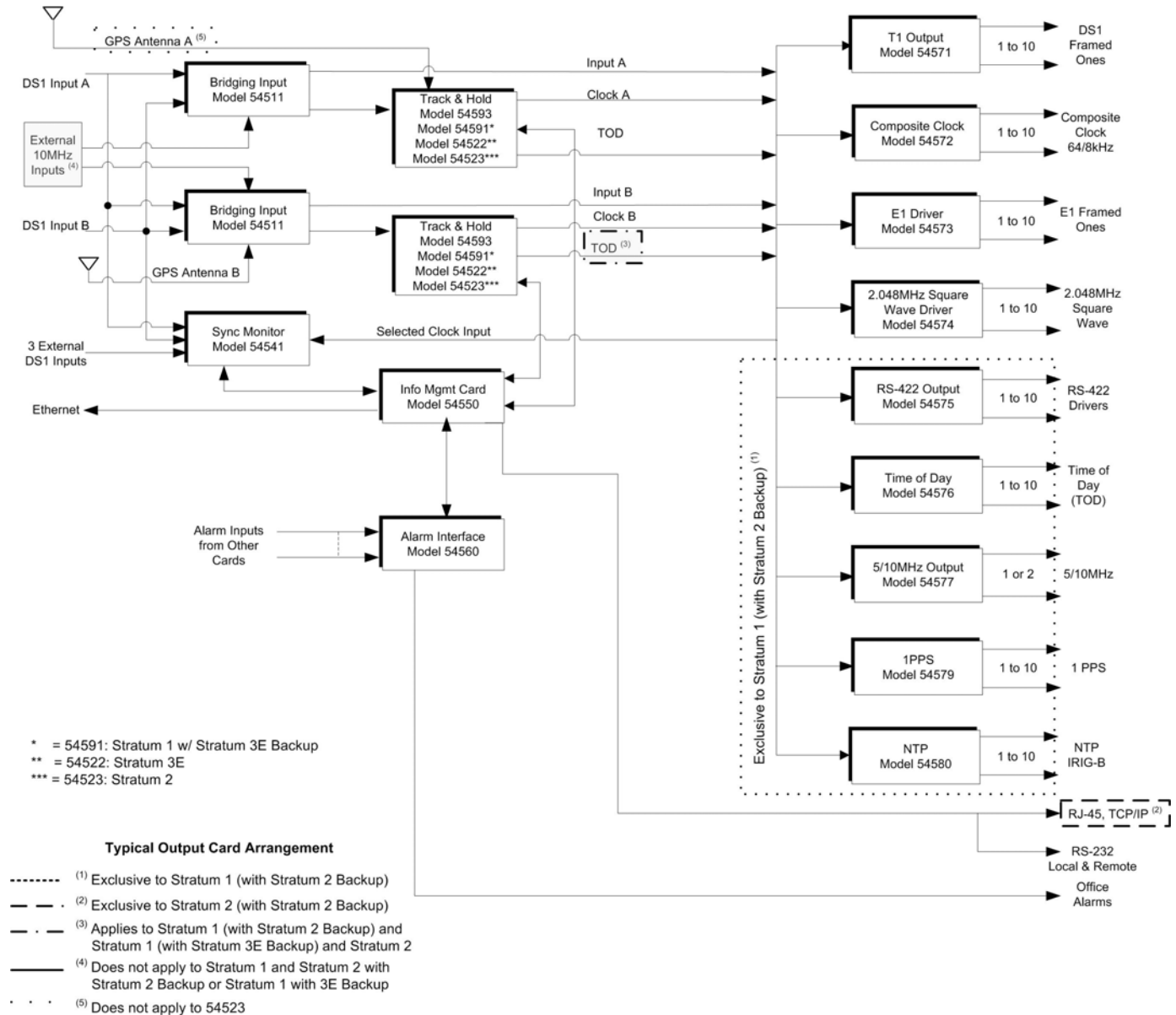

Other product and company names referenced herein may be trademarks or trade names of their respective owners. Features and specifications are subject to change without notice.